

“LIFE-OF-MINE PROCESS SIMULATION FROM DRILL HOLES TO NET PRESENT VALUE”

Alex Holtzapple, Proware, Tucson, AZ

John T. Bartlett, Proware, Tucson, AZ

Mike Botz, Elbow Creek Engineering, Billings, MT

Introduction

Life-of-mine process simulation is an interdisciplinary effort and a useful means of thoroughly evaluating mining and minerals projects. Communication between geologists, mine planners, miners, metallurgists, and managers not only benefits each discipline but facilitates design of an efficient operation and allows for accurate forecasting of productions and cash flow. By focusing on the key areas: geology; mine design; waste dumps; stockpiles; metallurgy; weather data; tailings disposal; using contours, block models, mine plans, process flowsheets, design criteria, operating and control strategies, maintenance schedules, and operating costs to perform detailed daily simulation from start-up to shut-down; a comprehensive understanding for all disciplines is achieved. Construction of a METSIM model that includes all test work and project data from drill holes through net present value calculations brings the pieces together to achieve optimum process design, minimize operating problems and eliminate the term “black box” from project meetings and discussions.

Drill-Hole Data

Drill-hole data are among the first pieces of information collected in a new mining project. Geostatistics uses these data to generate the mine block model which is then used to develop the mine plan. Importing not only the drill-hole locations but all data contained therein has two advantages in the dynamic simulation: i) data is available for all disciplines to review; ii) mathematical analyses can be run to check that

the mine models correspond to the drill-hole data. METSIM is not used to generate the block model or mine plan, but is a useful tool for metallurgists to understand the variations in the mineralogy in order to determine the impacts these variations will have on plant operations. As seen in Figure 1, mapping locations of drill holes on the mine block model provides a clearer picture of the reliability of the estimated data. Cross-sectional maps may also be viewed, which will include the color-coded mine blocks and any drill holes that were made near the latitude or longitude of the section.

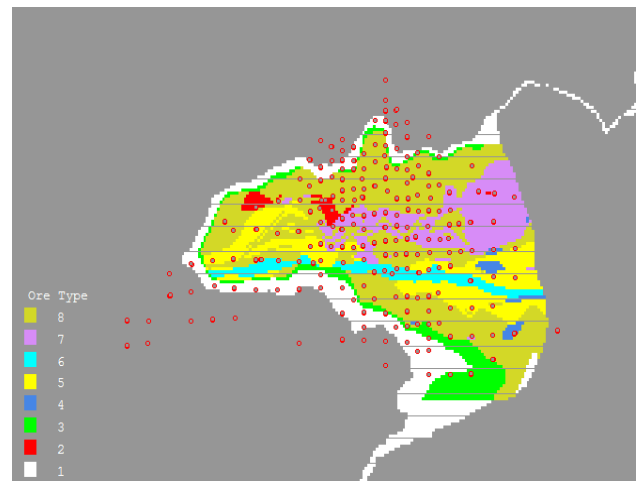

Figure 1: Map of drill-hole locations (shown by red circles) overlaying the mine block map. Mine blocks are color-coded based on ore type defined in the model.

Mine Data

Significant effort is required to organize the drill-hole data and metallurgical test-work into a detailed mine block model and mine plan. Normally, these data are then averaged into monthly, quarterly or annual tons and grade data and used for process plant design and economics. Why collect all these data, generate block models using geostatistics and hours of computer time, and then average the results into a few numbers? METSIM has the tools to read in the mine block model and mine plan, allowing for each block to be processed through the system from commissioning to shut-down, carrying with it all respective tonnages, mineralogy, assays, and metallurgical properties. METSIM does not currently generate mine block models, but imports these models from many widely-used mine planning software applications.

As seen in Figure 2, the mine may be viewed as two-dimensional plan view or cross-sections by elevation. All properties in the block model, such as ore type, geology, block destination, mineral and metal assays, etc. can be color-coded and displayed to better analyze the mine plan. Assigning a block destination gives the modeler the ability to designate which blocks are sent to waste, low-grade handling, high-grade handling, heap leaching, stockpiling, or plant, which are all included in the simulation. Additionally, equipment tracking systems can be linked to the model to track real-time block movement from mine to stockpile, plant or heap. This is useful for future stockpile reclaiming and processing of low grade stockpiles if and when they become economic.

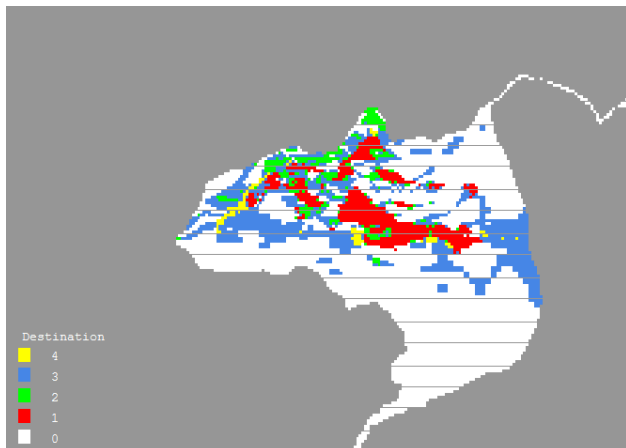

Figure 2: Map of the mine block model where the blocks are color-coded based on destination (plant, heap, waste, etc). Similar maps may be generated based on any block parameter, including ore type, mineral assay, geology, etc.

Metallurgical Testing

“Where is the metallurgical test-work data saved?” Unfortunately for most of us who ask this question, the answer is typically a combination of “I have just the...” or “I think he has...” or the dreaded “not sure...” Why collect all of these data if you are not going to use them? Given the efficiency with which METSIM can store large amounts of and all types of data, results from metallurgical testwork can be uploaded into the model, including: mineralogy, assays, particle size distributions, liberation sizes, crushing and grinding work indices, column leach tests, flotation tests, reagent consumptions, extraction and adsorption isotherms, etc. Using Dynamic Data Exchange, all of these data may be directly read into or out-of the model from any spreadsheet application. Design criteria and operating parameters can be linked to the model from spreadsheets.

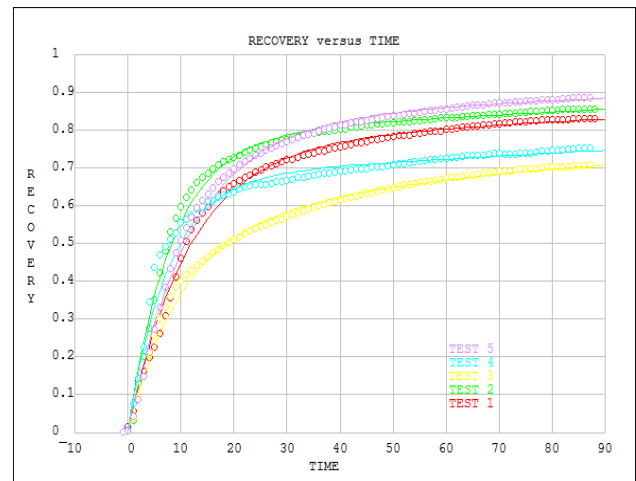

Figure 3: Plot of metal recovery curves versus time achieved through testwork and curve-fit in METSIM.

Recovery curves, such as those shown in Figure 3, are linked to the minerals throughout the process, not to the mine blocks. This method of calculating recovery takes into consideration variations in plant operating conditions, interactions between ore types, reagent concentrations, mineral liberations and other factors that may impact overall recovery, ensuring that the simulation accurately calculates how, when and where the metallurgy takes place.

Other metallurgical properties can be stored in the model in the mine blocks, data arrays, functions, or in flow streams, including screen analyses, hardness, clay content, reagent consumption, etc. Each of these play a key role in the process plant design and should be taken into consideration in the dynamic simulation.

Weather Data

Projects located in tropical and desert regions are immensely impacted by local weather conditions. Sites world-wide are investing millions of dollars to handle their excess water while others in dry regions go to great extreme to minimize water usage. Locations that have wet and dry seasons are faced with both problems and must have a plan in place to handle widely varying weather patterns. Dynamic simulation is the only tool for solving this major issue in plant design and operation.

The ability to include weather data in the process simulation is built into METSIM and allows users to enter historical regional weather data including temperatures, rainfall, evaporation, cloud cover, humidity, and wind velocity and direction by hour, day or month. A complete weather matrix is created from this data and referenced during dynamic simulations. Taking into account the local weather and its impact on a project translates into significant savings in process design and operation.

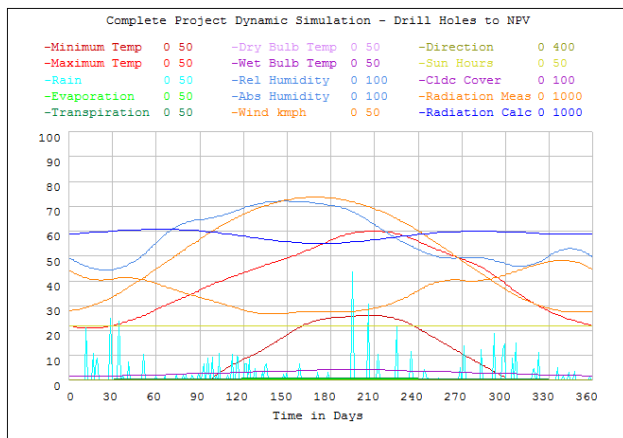

Figure 4: Plot of site weather data over a one year span, including temperatures, rainfall, evaporation, cloud cover, wind, and humidity.

Waste & Tailings Design

Similar to a mine block model, METSIM's ability to work with topographic contours facilitates development of block models of waste dumps, stockpiles and tailings ponds. Material flows, solids and liquid levels, liquor assays, and liquor discharges throughout these systems are calculated daily, not averaged as summer versus winter or dry versus rainy seasons. Precision of this magnitude provides a much clearer picture of the size and shape of disposal facilities and operating strategy for each project's waste handling.

Figure 5 shows the tailings contour map, used to generate the tailings block model. These contours are imported as dxf files.

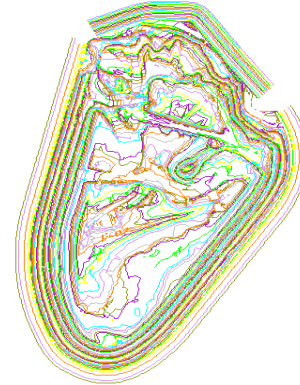

Figure 5: Tailings dam contours used to generate a block model of the waste facility.

Metallurgical Plant & Operating Parameters

Every project should undergo extensive process evaluation of equipment, material handling, piping, instrumentation, and control options. Process flow diagrams (PFDs), piping and instrumentation diagrams (P&IDs), design criteria, equipment specification sheets, and equipment lists must be generated during this phase. These documents are often stored in multiple locations, updated frequently, and are difficult to obtain when needed. Over 200 unit operation models are available in METSIM for use in the simulation of the metallurgical processing plant, from primary crushing through product load-out, as well as general data forms for equipment list generation and equipment specification sheets. Alternative processing options can be quickly simulated, thereby aiding in the design of the ideal plant.

Unlike a spreadsheet model, a dynamic simulation can be developed to include instrumentation and controls as well as the ability to adjust plant operating parameters and analyze their impacts on the process operation and over-all project results. Metal recovery and plant throughput is tracked with time as affected by varying material characteristics and ore grades. This provides specific production forecasts during the life of the project varying daily or monthly as opposed to annual averages. Design criteria can be tested and evaluated to determine if it applies to varying operating conditions. Steady-state mass balances can be generated for use in engineering design. Figure 6 illustrates a simple PFD.

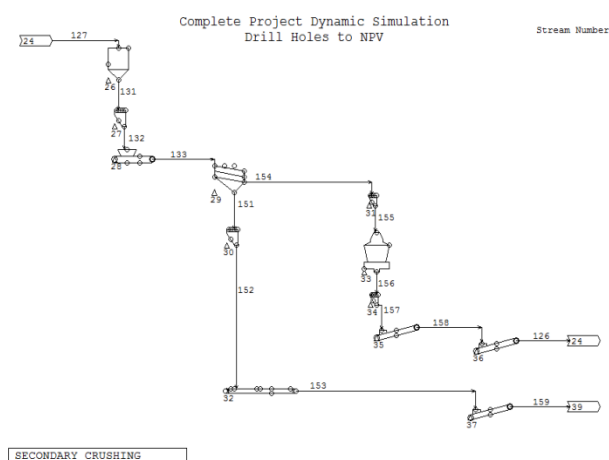

Figure 6: Screen shot from the METSIM simulation illustrating a simple crushing circuit.

Many processes are not adequately evaluated using a steady state model (i.e. strictly mass and heat balances) and are better suited to evaluation through dynamic simulation. Heap leaching, for example, involves complex interactions between different areas of the heap as well as the heap and process plant, and by its very nature, these interactions are time dependent.

A block model of the heaps can be added to the dynamic model using contours or simple grids. Solids and solutions are tracked in each block for each time step. Figure 7 illustrates a heap block model generated from contours. Optimizing heap design and recovery without dynamic simulation is difficult and often prone to error.

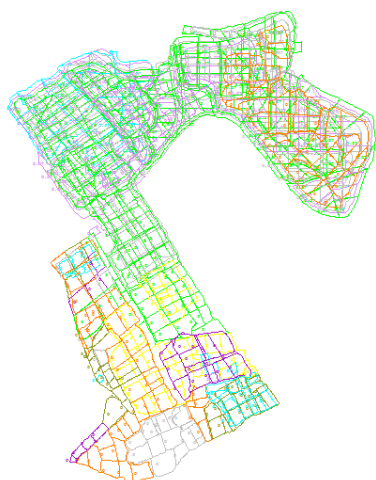

Figure 7: Example of contour files used to generate a heap leach block model in METSIM.

Optimization of heap design is only part of the task; operational strategies must also be thoroughly investigated to maximize plant efficiency. Tendencies to mine high grade ore first often result in oversized processing plants, driving up capital costs. In the case of a solvent extraction and electrowinning plant, which was designed for life-of-project averages, varying flows and/or grades over time create operational difficulties as well as decreasing recoveries. Dynamically simulating different leaching strategies (i.e. which cells to leach at what time), with the goal of maintaining constant feed to the process plant, benefits many aspects of the project. Optimum mine plans do not necessarily result in an overall optimum project. Dynamic simulation of the complete process is the key to improved performance.

Equipment Availability

Design of a processing plant must take into consideration equipment availability and operating time, a difficult task without conducting a dynamic simulation. Bottlenecks and under-designed equipment are readily identified with such a model. Scheduled maintenance and random breakdowns, along with ladder logic, similar to that used in control systems, are used to determine equipment availability. Availability is a major factor in the equipment design. Items in the plant with a fixed capacity or residence time, i.e. stockpiles, conveyors, bins, tanks, etc. are confirmed to be sized properly to handle unexpected variances in flowrates and downtime. Equipment utilization matrices can then be generated from the dynamic simulation, itemizing the availability and downtime, as illustrated in Figure 8.

EQUIPMENT UTILIZATION							
UNIT	EQUIPMENT	EQUIPMENT	AVAIL.	SCHED.	BREAK	CONTROL	TOTAL
OPER	NUMBER	DESCRIPTION	ONLINE	MNTCT.	DOWNS	LOGIC	HOURS
1	1000-SEC-0001	1000-PRIMARY CRUSHING	100	0	0	0	1144.7
2	1000-BIN-0001	FEED BIN	93.18	0	0	6.82	1112.9
3	1000-CVB-0001	BIN DSCH CONVEYOR	94.67	0	2.91	2.42	1144.7
4	1000-SCR-0001	PRIMARY SCREEN	83.49	0	2.45	14.07	1144.7
5	1000-CVB-0002	SCREEN U/S CONVEYOR	91.86	0	2.56	5.58	1144.7
6	1000-CVT-0001	SCREEN O/S CONVEYOR	87.53	0.17	2.99	9.31	1144.7
7	1000-CRG-0001	PRIMARY CRUSHER	90.53	0	0	9.47	1144.7
8	1000-CVB-0003	PRIM CRUSHER DSCH CONVEYOR	90.53	0	3.89	5.58	1144.7
9	1000-CVX-0001	STACKER	94.3	0	2.65	3.05	1144.7
10	1000-STK-0001	STOCKPILE	99.95	0	0.05	0	1110.2

Figure 8: Simplified equipment availability report which itemizes each piece of equipment and its downtime.

Operating Costs

Detailed operating costs can be developed for all items in the process since the dynamic model has daily information for every major equipment item and process flow stream. Costs for reagents, repair materials, energy, and man-hours are accumulated for each time period for each area throughout the mine and process plant. Examples include equipment maintenance costs, crusher liners, steel balls, flocculant, diesel fuel, truck tires, conveyor belts, administration costs, sulfuric acid and any other materials that enter or leave the site. These data are organized to generate a comprehensive cost analysis tool. Reports, such as the example shown in Figure 9, are then generated for easy analysis of operating costs and cash flow.

METSIM costing includes mining capital items. Given the many variables in plant capital costs, such as geographic location or current equipment prices, plant capital cost must be entered manually from other sources. As shown in Figure 9, the total capital cost is included in net present value calculations.

ITEMIZED COST REPORT BY AREA			
PERIOD:FROM MO/YR	1: 1/ 13	2: 1/ 14	3: 1/ 15
THRU MO-YR	Dec-13	Dec-14	Dec-15
10000 OVERBURDEN			
LABOR	\$95,457	\$95,094	\$94,562
MATERIAL	\$156,012	\$156,012	\$156,012
CAPITAL	\$112,565	\$110,295	\$85,995
AREA TOTAL	\$364,034	\$361,401	\$336,569
11000 HIGH GRADE ORE			
LABOR	\$162,057	\$172,295	\$191,408
MATERIAL	\$113,806	\$155,454	\$207,521
CAPITAL	\$56,875	\$69,585	\$72,465
AREA TOTAL	\$332,738	\$397,334	\$471,394
12000 LOW GRADE ORE			
LABOR	\$161,717	\$172,814	\$191,180
MATERIAL	\$113,567	\$155,922	\$207,273
CAPITAL	\$29,585	\$32,656	\$29,400
AREA TOTAL	\$304,869	\$361,392	\$427,853
TOTAL LABOR	\$419,231	\$440,203	\$477,150
TOTAL MATERIAL	\$383,385	\$467,388	\$570,806
TOTAL OPERATING COST	\$802,615	\$907,591	\$1,047,956
EQUIPMENT SALVAGE VALUE	\$0	\$0	\$0
INPUT CAPITAL COST	\$8,000,000	\$5,000,000	\$2,000,000
EQUIPMENT CAPITAL COST	\$1,368,000	\$456,000	\$0
CAPITAL	\$9,368,000	\$5,456,000	\$2,000,000
** TOTAL PROJECT COST	\$10,973,231	\$7,271,182	\$4,095,912

Figure 9: Example of a cost report generated for a three-year calculation, including operating costs for labor and materials as well as equipment capital costs.

Existing Operation Success

Dynamic simulation of existing projects has pointed out deficiencies in operations and proven to be a valuable tool in increasing plant capacities and metal recoveries.

In the case of one heap leach project, roughly 70 million tons of ore had been stacked over a five-year period. During this time, numerous changes in managerial and operational strategies, as well as personnel turnover, had left the heap in a confused state of operation. The result was a heap with an estimated 70,000 tonnes of recoverable metal and 10,000 tonnes of dissolved metal in inventory. The exact location of this metal was in question.

Using survey data, a three-dimensional block model of the heap was created. This METSIM model was used to dynamically simulate each day of the operation over the life of the heap using all available data, drawings and production information. Metallurgical tests were used to calibrate the model to ensure actual data for flows, grades and production agreed with the model results within 2%. The model maps of the metal locations, at all elevations, were used to focus leaching efforts on specific cells to recover the dissolved metal and to leach cells that had been inadequately treated in prior operations. Ultimately, this optimized the overall plant production.

Conclusion

In conclusion, varying ore types and grades, alternative mine plans, process designs and operating philosophies, as well as fluctuating costs can be used in a dynamic model of the complete process. Use of available data from all disciplines in one interactive model facilitates the optimization of short and long-term planning, helps to locate potential problems, and results in the optimum project design and operation. Life-of-mine process simulation provides the tool necessary for this level of project development.